

United States Court of Appeals for the Federal Circuit

03-1230, -1249

NOVO INDUSTRIES, L.P.,

Plaintiff-Cross Appellant,

v.

MICRO MOLDS CORPORATION,

Defendant-Appellant,

and

OSCAR HELVER,

Defendant.

James H. Riley II, Sonnenschein Nath & Rosenthal LLP, of Kansas City, Missouri, argued for plaintiff-cross appellant.

Michael C. Cesarano, Akerman, Senterfitt, of Miami, Florida, argued for defendant-appellant.

Appealed from: United States District Court for the Southern District of Florida

Judge Paul C. Huck

United States Court of Appeals for the Federal Circuit

03-1230, -1249

NOVO INDUSTRIES, L.P.,

Plaintiff-Cross Appellant,

v.

MICRO MOLDS CORPORATION,

Defendant-Appellant,

and

OSCAR HELVER,

Defendant.

DECIDED: December 5, 2003

Before CLEVINGER, GAJARSA, and DYK, Circuit Judges.

DYK, Circuit Judge.

Micro Molds Corporation (“Micro Molds”) appeals the decision of the United States District Court for the Southern District of Florida holding that Micro Molds infringed U.S. Patent No. 5,056,578 (“the ’578 patent”), entitled “Carrier Structure for a Vertical Blind Assembly,” and awarding enhanced damages to the patent’s assignee, Novo Industries L.P. (“Novo”). Novo Indus., L.P. v. Micro Molds Corp., 239 F. Supp. 2d 1282 (S.D. Fla. 2002). Because the district court lacked authority to “correct” claim 13 of the ’578 patent by construing the word “a” to mean “and,” we reverse the district court’s decision as to infringement. In addition, we hold claim 13 of the ’578 patent in its present form invalid for

indefiniteness under 35 U.S.C. § 112, ¶ 2. Finally, we deny Micro Molds' request for sanctions against Novo.

BACKGROUND

I

Novo is the assignee of the '578 patent, which is directed to a carrier assembly that holds one of a plurality of vertical slats (or blinds) that cover the interior of a window. Figure 1 of the patent is reproduced below:

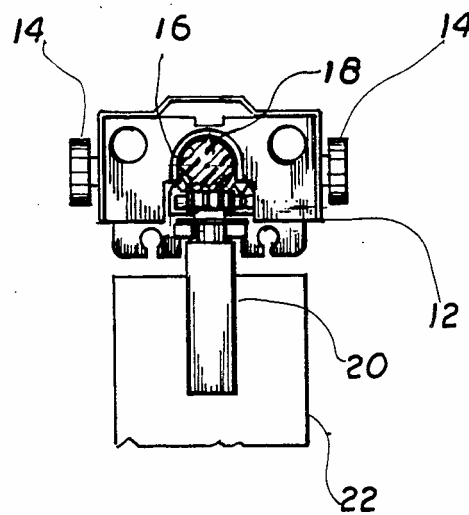

FIG. 1

Typically, the slats have a large width relative to their thickness. In use, a plurality of the carrier assemblies are supported on a horizontal "tilt rod" 18 that runs across the top of the window. Each carrier assembly contains a gearing mechanism that causes a support finger 20 holding the slat 22 to rotate about the support finger's vertical axis when the tilt rod is rotated. The rotation of the support finger causes the slat to rotate about its own vertical axis, permitting more or less light to pass the slat as its angle relative to the window is changed.

Because each carrier assembly is typically linked to a single tilt rod, rotation of the tilt rod causes all of the slats to rotate simultaneously. Generally, all of the slats are aligned

at the same angle with respect to the window. When a chain is pulled or a similar drive mechanism is engaged, the tilt rod rotates, opening or closing all of the slats in unison. Occasionally, however, one or more of the slats becomes misaligned from the other slats, causing one of the adjacent slats to come into contact with the misaligned slat, which can inhibit further rotation of the slat as the tilt rod is rotated. The '578 patent is directed to a carrier assembly that permits realignment (or "self-alignment") of misaligned slats in such a situation. The carrier assembly includes stop mechanisms that physically prevent further rotation of the support finger when the slat reaches an extreme rotational position. Thus, when a misaligned slat reaches the extreme rotational position (e.g., when the slat is parallel to the window), it will stop rotating, even as the tilt rod continues to rotate. Because the misaligned slat cannot rotate, its gears skip as the tilt rod rotates, until the remaining properly aligned slats reach the extreme rotational position. Thus, the misaligned slat will be forced into alignment at the extreme rotational position with the other slats. All of the slats can then be adjusted in unison to any desired angle.

The original patent application that matured into the '578 patent included seventeen claims. Claims 15-17 read:

15. A carrier assembly for movably supporting one of a plurality of vertical oriented slats in a vertical blind assembly, said carrier assembly comprising:

a) a frame having an opening formed therein and disposed and dimensioned to rotatably receive a splined tilt rod therein in substantially transverse relation to the frame,

b) a support finger movably mounted to rotate on said frame about its own longitudinal axis and being removably and supportingly attached to an upper end of one slat,

c) a gear means drivingly interconnecting the tilt rod to the support finger for rotation of the support finger and the slat attached thereto upon rotation of the tilt rod,

d) said gear means comprising a drive gear formed on said support finger and further comprising a drive gear connected in driven engagement to the tilt rod and a second gear connected in driving engagement to said drive gear and said support finger and movable with said first gear upon rotation of the tilt rod,

- e) said first gear and said second gear fixedly connected to one another and movable with one another upon rotation of the tilt rod, and
- f) said first and second gear forced into continued longitudinal movement relative to said drive gear upon forced rotation of said tilt rod and fixed positioning of said drive gear relative to said frame.

16. An assembly as in claim 15 further comprising stop means formed on said support finger and extending outwardly therefrom into engaging relation with one of two spaced apart stop members formed on said frame.

17. An assembly as in claim 16 wherein said stop means comprises one outwardly extending protrusion disposed to engage each of said stop members on said frame on rotation through an arc of 180 degrees.

(App. at A222-23 (emphasis added).) Claim 15 was rejected under 35 U.S.C. § 102(b) as anticipated by U.S. Patent No. 4,848,435 to Helver ("Helver"), and claims 16 and 17 were rejected under 35 U.S.C. § 103 as being unpatentable over Helver in view of U.S. Patent No. 4,834,163 to Dickstein ("Dickstein"). The examiner stated that Helver disclosed all of the limitations of claim 15 and that, "while Helver does not disclose a stop means disposed on the support finger, Dickstein discloses a stop means 52 on a support finger 28, wherein, to incorporate this teaching into the support finger of Helver for the purpose of limiting the rotational movement of the slats would have been obvious to one of ordinary skill in the art." (App. at A226-27.)

In response to the rejection, the applicant cancelled claims 15-17 and substituted claim 19, which read:

19. A carrier assembly for movably supporting one of a plurality of vertical oriented slats in a vertical blind assembly, said carrier assembly comprising:

- a) a frame having an opening formed therein and disposed and dimensioned to rotatably receive a splined tilt rod therein in substantially transverse relation to the frame,

- b) a support finger movably mounted to rotate on said frame about its own longitudinal axis and being removably and supportingly attached to an upper end of one slat,

- c) a gear means drivingly interconnecting the tilt rod [sic] to the support finger for rotation of the support finger and the slat attached thereto upon rotation of the tilt rod,

- d) said gear means comprising a drive gear formed on said support finger and further comprising a first gear connected in driven engagement to the tilt rod and a second gear connected in driving engagement to said drive

gear and said support finger and movable with said first gear upon rotation of the tilt rod,

e) said first gear and said second gear fixedly connected to one another and movable with one another upon rotation of the tilt rod,

f) said first and second gears forced into continued longitudinal movement relative to a fixed positioning of said drive gear relative to said frame and a continuing forced rotation of said tilt rod,

g) stop means formed on a rotatable with said support finger and extending outwardly therefrom into engaging relation with one of two spaced apart stop members formed on said frame,

h) said stop means comprising one outwardly extending protrusion disposed to engage each of said stop members on said frame upon rotation through an arc of substantially 180 degrees, and

i) said drive gear including a substantially round configuration and a plurality of gear teeth formed thereon in spaced relation to one another along an outer periphery of said drive gear to define a circular configuration thereof; said second gear comprising a plurality of gear teeth linearly arranged in spaced relation along the length of said base; said gear teeth of said second gear forced into successive engagement and displacement relative to said gear teeth of said drive gear upon said continued longitudinal movement of said base and said first and second gears relative to said fixed positioning of said drive gear.

(App. at A232-33 (emphasis added).)

Claim 19 thus incorporated the limitations of cancelled claims 15 and 17 as paragraphs (a)-(f) and (h), respectively, and it included new paragraph (i). However, the language of paragraph (g) of claim 19 was not identical to that of cancelled claim 16. Rather, it included the additional words “a rotatable with” that did not appear in claim 16 of the original application. The examiner allowed claim 19, which became claim 13 of the issued patent. Although the parties now agree that claim 13 included an error, Novo never sought or obtained a certificate of correction pursuant to 35 U.S.C. § 255 from the United States Patent and Trademark Office (“PTO”).

II

In 1999, Novo commenced this action against Micro Molds, asserting infringement of claim 13 of the '578 patent. The parties disputed the meaning of the words “a rotatable with” in claim 13. Novo argued that the claim included an obvious typographical error that

could be corrected by construction in one of two ways. First, Novo argued that the claim could be “corrected by deleting three superfluous words (a rotatable with)” from the claim to make it read: “stop means formed on said support finger.” (App. at A180.) Alternatively, Novo argued that “the error could be corrected by deleting two words (with said)” from the claim to make it read: “stop means formed on a rotatable support finger.” (App. at A180 n.1.) In contrast, Micro Molds argued that the addition of the words “a rotatable with” to the claim indicated that the applicant had abandoned coverage of a stop means on the support finger itself and therefore that the claim could not be construed to include a stop means on the support finger. Rather, the stop means had to be located on a separate “rotatable.” Because the “rotatable” is not identified, Micro Molds argued, the claim is invalid for indefiniteness. After a Markman hearing, the district court issued an order construing claim 13. Novo Indus., L.P. v. Micro Molds Corp., No. 99-6465-CIV-HUCK-BROWN (S.D. Fla. Sept. 26, 2001) (“Markman Order”). The district court rejected both parties’ arguments, instead construing the claim as follows:

Claim 13(g) means:

The mechanism for stopping the rotation of the drive gear is a part which is formed on and is rotatable with (rotates in unison with) the support finger. This part extends out from the support finger so that it comes into contact with either one of the two stop members which are formed on and spaced apart from one another on the carrier assembly frame.

...

The Court finds that this is the proper interpretation regardless of whether a) the word “a” is interpreted as “and”, as Novo suggests, and the Court agrees, because of an obvious typographical error; or b) whether one ignores that error, and where, as here, the word “rotatable” is used as a noun, indicating a part that rotates in unison with and is located on the support finger, as established by and used in the literal wording of Claim 13(g).

Markman Order, slip op. at 2 (emphasis added).

The district court instructed the jury to interpret the paragraph in accordance with this construction, telling the jury over Micro Molds' objection that "[t]he claim language includes an obvious typographical error, 'a' should be read as –and–." (App. at 100.) The district court thus did not reach the issue of invalidity for indefiniteness. The jury found that Micro Molds had literally infringed the '578 patent and that Micro Molds was guilty of willful infringement.

After the jury trial, Micro Molds filed for bankruptcy. The bankruptcy court granted limited relief from the automatic stay, and the district court entered judgment against Micro Molds for infringement of the '578 patent on December 23, 2002. Novo Indus., L.P. v. Micro Molds Corp., No. 99-6465-CIV-HUCK-BROWN (S.D. Fla. Dec. 23, 2002) ("Final Judgment"). The court also denied Micro Molds' motion seeking judgment as a matter of law and a new trial because of the district court's allegedly erroneous claim construction. Novo Indus., 239 F. Supp. 2d at 1284. Furthermore, after considering the factors that we set out in Read Corp. v. Portec, Inc., 970 F.2d 816, 826-27 (Fed. Cir. 1992), for enhanced damages pursuant to 35 U.S.C. § 284, the district court awarded Novo enhanced damages, doubling the amount of actual damages. Novo Indus., 239 F. Supp. 2d at 1289-91.

Micro Molds timely appealed, and the bankruptcy court entered an order permitting the appeal to proceed.¹ See Novo Indus., L.P. v. Micro Molds Corp., Nos. 03-1320, -1249 (Fed. Cir. July 30, 2003) (order denying Novo's motion to dismiss). We have jurisdiction pursuant to 28 U.S.C. § 1295(a)(1).

DISCUSSION

We review a district court's claim construction as a matter of law without deference. E-Pass Techs., Inc. v. 3Com Corp., 343 F.3d 1364, 1367 (Fed. Cir. 2003); Cybor Corp. v.

FAS Techs., Inc., 138 F.3d 1448, 1456 (Fed. Cir. 1998) (en banc). “If the court determines that a claim is not ‘amenable to construction,’ then the claim is invalid as indefinite under 35 U.S.C. § 112, ¶ 2.” Honeywell Int’l, Inc. v. Int’l Trade Comm’n, 341 F.3d 1332, 1338 (Fed. Cir. 2003) (quoting Exxon Research & Eng’g Co. v. United States, 265 F.3d 1371, 1375 (Fed. Cir. 2001)).

I

This case presents the question whether a district court can act to correct an error in a patent by interpretation of the patent where no certificate of correction has been issued. We hold that a district court can do so only if (1) the correction is not subject to reasonable debate based on consideration of the claim language and the specification and (2) the prosecution history does not suggest a different interpretation of the claims. We conclude that this is not a case in which correction by the district court was appropriate.

A

Many years before the enactment of 35 U.S.C. §§ 255² and 254,³ which provide for corrections of mistakes by the patentee (section 255) and the PTO (section 254), the

¹ Novo also filed a cross-appeal, which it later withdrew.

² Section 255 provides:

Whenever a mistake of a clerical or typographical nature, or of minor character, which was not the fault of the Patent and Trademark Office, appears in a patent and a showing has been made that such mistake occurred in good faith, the Director may, upon payment of the required fee, issue a certificate of correction, if the correction does not involve such changes in the patent as would constitute new matter or would require re-examination. Such patent, together with the certificate, shall have the same effect and operation in law on the trial of actions for causes thereafter arising as if the same had been originally issued in such corrected form.

35 U.S.C. § 255 (2000).

³ Section 254 provides:

Supreme Court held that, in a patent infringement suit, the courts could properly interpret a patent to correct an obvious error. I.T.S. Rubber Co. v. Essex Rubber Co., 272 U.S. 429 (1926) (“Essex”). In Essex, claim 8 of U.S. Patent No. RE 14,049 (“the ‘049 patent”), entitled “Resilient Heel,” read:

A heel lift of resilient material comprising a body portion of uniform thickness throughout its entire area and of concavo-convex form on every line of cross section, the concave upper face of the lift lying entirely below a plane passing through the upper edge and the breast corners of said lift.

’049 patent at p. 3, ll. 72-79 (emphasis added). Claim 8 thus defined the plane with reference only to the “upper edge” of the lift, unlike related claims 5, 6, 7, and 9, which defined the plane as “passing through the rear upper edge and the breast corners of the lift,” id. at p. 3 ll. 46-49, 53-55, 63-66, 83-86 (emphasis added). The Supreme Court upheld the district court’s correction of the patent to include the word “rear” in claim 8 of the ’049 patent. Essex, 272 U.S. at 441-42. The Court held that “the fact that the word ‘rear’ does not appear before the words ‘upper edge’ in claim 8 is not a ground upon which it may be differentiated from the others [i.e., the other claims]. It appears that this omission was inadvertent and unnoticed.” Id. at 441. In addition to considering the face of the patent, the Supreme Court also considered the prosecution history and found that it supported the same conclusion:

Whenever a mistake in a patent, incurred through the fault of the Patent and Trademark Office, is clearly disclosed by the records of the Office, the Director may issue a certificate of correction stating the fact and nature of such mistake, under seal, without charge, to be recorded in the records of patents. A printed copy thereof shall be attached to each printed copy of the patent, and such certificate shall be considered as part of the original patent. Every such patent, together with such certificate, shall have the same effect and operation in law on the trial of actions for causes thereafter arising as if the same had been originally issued in such corrected form. The Director may issue a corrected patent without charge in lieu of and with like effect as a certificate of correction.

We concur in the finding of the District Judge that the omission of the word “rear” was through a clerical error due to oversight, and that both the counsel for the applicant and the examiner understood that it was contained in claim 8 as well as the others; and we are of opinion that the claim should be construed and have the same effect as if it had been included. This is not in any real sense, a re-making of the claim; but is merely giving to it the meaning which was intended by the applicant and understood by the examiner.

Id. at 442. The Court held that construing the claim not to include the word “rear” would “render the claim invalid as being for a different invention from that described in the specification and drawings of the original patent. And so construed, it would not read on the specification and drawings of the re-issued patent.” Id. at 442-43 (citations omitted). Thus, under Essex, certain obvious errors in the patent can be corrected by the district court in construing the patent.

B

The Patent Act of 1952, Pub. L. No. 82-593, 66 Stat. 792, added section 255 to Title 35 and revised section 254, 66 Stat. at 809-10. Nothing in the enactment of either section 255 or 254 suggests that Congress intended to overrule Essex or to deny limited correction authority to the district courts. Rather, the committee reports stated only that the additions were similar to trademark provisions then codified at 15 U.S.C. § 1057(f)-(g).⁴

⁴ These provisions were enacted by subsections 7(f) and (g) of the Trademark Act of 1946, Pub. L. No. 79-489, § 7, 60 Stat. 427, 430-31. Subsections (f) and (g) are now codified at 15 U.S.C. § 1057(g)-(h). See Trademark Law Revision Act of 1988, Pub. L. No. 100-667, § 109, 102 Stat. 3935, 3938. They provide:

S. Rep. No. 82-1979, at 27 (1952), reprinted in 1952 U.S.C.C.A.N. 2394, 2420; H.R. Rep. No. 1923, at 27. Under such circumstances, we presume that Congress did not intend to alter the existing judicial interpretation of the patent statute. See, e.g., Lorillard v. Pons, 434 U.S. 575, 580-81 (1978); Elec. Storage Battery Co. v. Shimadzu, 307 U.S. 5, 14 (1939).

Indeed, sections 255 and 254 themselves suggest that they were not intended to address the authority of the district courts to correct patents by construction where no certificate of correction has been issued by the PTO. Those sections deal only with the authority of the PTO to make prospectively effective corrections, and the PTO was given no authority to correct the claims retroactively. Section 255 states, "Such [corrected] patent, together with the certificate, shall have the same effect and operation in law on the trial of actions for causes thereafter arising as if the same had been originally issued in such

(g) Correction of Patent and Trademark Office mistake. Whenever a material mistake in a registration, incurred through the fault of the Patent and Trademark Office, is clearly disclosed by the records of the Office a certificate stating the fact and nature of such mistake, shall be issued without charge and recorded and a printed copy thereof shall be attached to each printed copy of the registration certificate and such corrected registration shall thereafter have the same effect as if the same had been originally issued in such corrected form, or in the discretion of the Director a new certificate of registration may be issued without charge. All certificates of correction heretofore issued in accordance with the rules of the Patent and Trademark Office and the registrations to which they are attached shall have the same force and effect as if such certificates and their issue had been specifically authorized by statute.

(h) Correction of applicant's mistake. Whenever a mistake has been made in a registration and a showing has been made that such mistake occurred in good faith through the fault of the applicant, the Director is authorized to issue a certificate of correction or, in his discretion, a new certificate upon the payment of the prescribed fee: Provided, That the correction does not involve such changes in the registration as to require republication of the mark.

15 U.S.C. § 1057 (2000).

corrected form.” 35 U.S.C. § 255. Section 254 is substantially similar in this respect.⁵ As we held in Southwest Software, Inc. v. Harlequin Inc., 226 F.3d 1280 (Fed. Cir. 2000), under sections 254 and 255, a “certificate of correction is only effective for causes of action arising after it was issued.” Id. at 1294. For causes of action that arise before the correction becomes effective, the patent must be considered without the benefit of the certificate of correction. See id. at 1297 (remanding the case for the district court to consider whether the claim-in-suit was invalid before the certificate of correction was issued). Thus, if we were to hold that the district court was powerless to correct any and all errors when construing the patent, every patent containing an error that makes a claim indefinite would be invalid until and unless corrected by the PTO. At the same time, the PTO properly refuses to correct truly minor errors in the section 255 process. See Manual of Patent Examining Procedure § 1485 (8th ed. 2001) (“[D]etermination as to whether . . . the error is of such a nature as to justify the issuance of a Certificate of Correction will be made by the Certificate of Correction Branch.”); 3 Lester Horwitz, Patent Office Rules and Practice § 323[A][1] (2003) (“Mistakes which are too trivial, inconsequential, or obviously recognized will not warrant the issuance of a certificate of correction.”). We see no evidence that Congress intended to impose such a draconian result (barring any corrections by the district court) by the enactment of sections 255 and 254 or to change existing law in this respect.

C

Although we conclude that Congress intended to preserve the authority of the district courts to correct errors, we do not think that Congress intended that the district courts have

⁵ “Every such [corrected] patent, together with such certificate, shall have the same effect and operation in law on the trial of actions for causes thereafter arising as if the same had been originally issued in such corrected form.” 35 U.S.C. § 254.

the authority to correct any and all errors that the PTO would be authorized to correct under sections 254 and 255. First, there is the fact that sections 254 and 255, in contrast to 35 U.S.C. § 256, which deals with correction of inventorship, do not give the district courts the same authority as the PTO. Section 256 expressly provides that a district court “may order correction of the patent on notice and hearing of all parties concerned and the Director shall issue a certificate accordingly.” 35 U.S.C. § 256 (2000). In contrast, “[s]ection 255 [like section 254] does not provide for action by a district court. Rather, the statute permits only the Director to issue a certificate of correction for a clerical error.” Fina Tech., Inc. v. Ewen, 265 F.3d 1325, 1328 (Fed. Cir. 2001). Second, the authority of the PTO to make corrections under section 255, while limited to review of the intrinsic record, Superior Fireplace Co. v. Majestic Prods. Co., 270 F.3d 1358, 1373 (Fed. Cir. 2001), is not limited to obvious errors. Rather, it extends even to broadening corrections, so long as “it is clearly evident from the specification, drawings, and prosecution history how the error should appropriately be corrected.” Id. Third, where the error is not evident from the face of the patent itself, as it was in Essex, it is important that the PTO bring its expertise to bear and consider whether such a correction is appropriate. Finally, to allow the district court to correct such errors would effectively write the nonretroactivity provisions out of sections 254 and 255. The district court always would apply its own corrections retroactively in the action before it, unlike certificates of correction issued by the PTO, which apply only in actions brought after the certificate of correction is issued, see Southwest Software, 226 F.3d at 1297.

This view of the respective authorities of the district courts and the PTO in this area is confirmed by our prior decisions. After the enactment of sections 254 and 255, we have assumed that courts can continue to correct obvious minor typographical and clerical errors in patents. See Lemelson v. Gen. Mills, Inc., 968 F.2d 1202, 1203 & n.3 (Fed. Cir.

1992) (adding the word “toy” to the preamble of a claim because “[t]he deletion of ‘toy’ appears from the record of the proceedings before the PTO to have been an inadvertent error when the patent was printed rather than an amendment to the claim”). At the same time, we have assumed that major errors are subject only to correction by the PTO. We assumed in Southwest Software that the district court itself could not correct the error there – the omission of an appendix containing approximately 330 pages of text – even though the PTO had appropriately done so. See 226 F.3d at 1296-97.

We therefore conclude that the district court can correct only Essex-type errors. A district court can correct a patent only if (1) the correction is not subject to reasonable debate based on consideration of the claim language and the specification and (2) the prosecution history does not suggest a different interpretation of the claims.

D

The present case does not fall within the ambit of the district court’s authority, for the nature of the error is not apparent from the face of the patent. Indeed, Novo itself suggested two different corrections to the district court: (1) deletion of the words “a rotatable with” from the claim or (2) deletion of the words “with said” from the claim. The interpretation by the district court, which changed the word “a” to “and,” raised still a third possibility. Most important, as Micro Molds suggests, the correct approach might be to add a word that was missing, such as “skirt” or “disk.” Although Novo argues that the reference in the specification to “a drive gear 26 mounted on and rotatable with an upper end of support finger 20,” (Novo Br. at 21 (emphasis added by Novo)), and the figures of the patent support the district court’s construction, these references do not provide the necessary clarity to overcome the ambiguity of the claim.

Furthermore, the prosecution history undermines Novo’s argument. Original claim 16, which included the “stop means formed on said support finger” limitation, was the

subject of a prior art rejection. The examiner rejected claim 16 under 35 U.S.C. § 103 as being unpatentable over Helver in view of Dickstein, stating that, “while Helver does not disclose a stop means disposed on the support finger, Dickstein discloses a stop means 52 on a support finger 28, wherein, to incorporate this teaching into the support finger of Helver for the purpose of limiting the rotational movement of the slats would have been obvious to one of ordinary skill in the art.” (App. at A227 (emphasis added).) In response to the rejection, the applicant deleted claim 16 and added claim 19, which included the present “stop means formed on a rotatable with said support finger” language. Although claim 19 also included an additional limitation in paragraph (i), the addition of the words “a rotatable with” to paragraph (g) clearly suggests that the additional language was not merely cosmetic, but had substantive significance. Under these circumstances, in order to make sense out of the patent, the district court was required to guess as to what was intended. That is beyond its authority.

Since we cannot know what correction is necessarily appropriate or how the claim should be interpreted, we must hold claim 13 of the '578 patent invalid for indefiniteness in its present form. Although in Southwest Software we remanded for the district court to determine whether the patent claim was invalid without the certificate of correction, 226 F.3d at 1297, we need not do so here. The error in Southwest Software did not exist in the claim language itself, as it does here; rather, the potentially invalidating error was the omission of an appendix containing approximately 330 pages of text from the specification. Id. at 1296. Thus, the issues for invalidity in Southwest Software were whether “the patent’s specification fail[ed] to satisfy the best mode and enablement requirements of 35 U.S.C. § 112, ¶ 1,” id. at 1297, not whether the claim language itself was indefinite under 35 U.S.C. § 112, ¶ 2. If a correction cannot be made, the claim here is invalid for indefiniteness under section 112, ¶ 2. See Honeywell Int’l, 341 F.3d at 1338;

Omega Eng'g Inc. v. Raytek Corp., 334 F.3d 1314, 1320-21 (Fed. Cir. 2003) (“Determining whether a claim is definite requires an analysis of ‘whether one skilled in the art would understand the bounds of the claim when read in light of the specification.’” (quoting Miles Labs., Inc. v. Shandon Inc., 997 F.2d 870, 875 (Fed. Cir. 1993))). The claim is invalid for indefiniteness because it is “insolubly ambiguous” and not “amenable to construction.” Exxon Research & Eng'g, 265 F.3d at 1375. Because claim 13 is clearly invalid for indefiniteness in its present form, we need not remand to the district court in this case.

II

Micro Molds argues that Novo should be subject to sanctions. There is no basis for an award of sanctions. Our authority to impose sanctions generally arises from Federal Rule of Appellate Procedure 38 (“Rule 38”), which permits sanctions for frivolous appeals. Construing Micro Molds’ request as arising under Rule 38, we deny Micro Molds’ claim for sanctions, for Novo’s position in this difficult case was far from frivolous. In addition, Micro Molds’ suggestion that the district court should have awarded sanctions is foreclosed by Micro Molds’ failure to raise this issue in the district court. See Singleton v. Wulff, 428 U.S. 106, 120 (1976) (“It is the general rule, of course, that a federal appellate court does not consider an issue not passed upon below.”); Interactive Gift Express, Inc. v. Compuserve Inc., 256 F.3d 1323, 1344 (Fed. Cir. 2001). In any event, just as Novo’s positions in this court were not frivolous, so too its arguments in the district court were not sanctionable. Therefore, Micro Molds is not entitled to sanctions against Novo in either this court or the district court.

CONCLUSION

For the foregoing reasons, we reverse the district court’s decision and hold claim 13 of the ’578 patent invalid for indefiniteness in its present form.

REVERSED

COSTS

No costs.